



GPU Nuclear Corporation
Post Office Box 480
Route 441 South
Middletown, Pennsylvania 17057-0191
717 944-7621
TELEX 84-2386
Writer's Direct Dial Number:
(717) 948-8461

January 10, 1989
4410-88-L-0183/0159P

US Nuclear Regulatory Commission
Attn: Document Control Desk
Washington, DC 20555

Dear Sirs:

Three Mile Island Nuclear Station, Unit 2 (TMI-2)
Operating License No. DPR-73
Docket No. 50-320
Sediment Transfer and Processing Operations Safety Evaluation Report,
Revision 4

Attached for your information is Revision 4 to the Sediment Transfer and Processing (STP) Operations Safety Evaluation Report (SER). Modifications to this SER, described in the "Summary of Change" section on Page 2.0 of this document, are highlighted below:

- o Reflects that the Submerged Demineralizer System (SDS) has been decommissioned and the EPICOR II System is currently utilized for activities previously performed by the SDS;
- o Updates the current and projected person-rem exposure for this system described in Section 3.0 of this SER;
- o Updates the physical description of the STP System to reflect modifications which enhance system performance.

To assist in your review, changes associated with this revision are indicated by margin bars in the body of the SER.

Sincerely,

M. B. Roche
Director, TMI-2

RDW/emf

8901240400 890110
PDR ADOCK 05000320
P PDC

Aool
/

Attachment

cc: R. J. Conte - Senior Resident Inspector, TMI
W. T. Russell - Regional Administrator, Region I
J. F. Stolz - Director, Plant Directorate IV
L. H. Thonus - Project Manager, TMI Site

SAFETY ANALYSIS

SA No. 4340-3233-87-088

Rev. No. 4

Page 1

of 40

TITLE

SAFETY EVALUATION REPORT

FOR

SEDIMENT TRANSFER AND PROCESSING OPERATIONS

Originator R. Malla Date 12/12/88

CONCURRENCE

Lead Engineer M. Khan Date 12/15/88 SRG J. J. Bavelier Date 1/4/89

RTR R. Malla Date 12-15 88

Design Cognizant Engineer R. Malla Date 12/12/88 Rad Con J. J. Bavelier Date 12-21-88

8901240409 890110
PDR ADOCK 05000320
PDC

Mgr Eng. Section J. J. Bavelier Date 1/4/89

Site Ops Director J. J. Bavelier Date 1/4/89

Title

Safety Evaluation Report for Sediment Transfer & Processing Operations

Rev.	SUMMARY OF CHANGE	Approval	Date
0	Issued for use.	<i>mm</i>	3/86
1	Revised to permit supernatant liquid from the concentrated sediment to be transferred directly back to the Reactor Building basement without being held in the neutralizer tanks.	<i>mm</i>	6/86
2	Revised to permit supernatant from AFHB and RB process operations to be discharged to the Reactor Building	<i>mm</i>	2/87
	Revised to reflect upgrade of the Decon Process Water System	<i>mm</i>	
	Revised to increase the person-rem exposure estimates for system installation and testing.	<i>mm</i>	
	Revised to delete the redundant level monitors in the SRSTs.	<i>mm</i>	
3	Revised to increase the person-rem exposure estimates for system installation and testing.	<i>mm</i>	11/87
4	Revised chemical addition options (MMA 3233-87-0029). Revised to include addition of solids handling pipeline delumper (MMA 3233-88-0111 and MMA 3233-88-0114). Revised to update recirculation line sampling connection description. Revised to clarify decant filters differential pressure monitoring (MMA 3233-87-0053). Revised to include air sparging of SRSTs (MMA 3233-88-0092). Revised to delete requirements for radiation monitors in the SRST cubicles and on the SRST overflow lines. Revised to update interfaces with existing plant systems (MMA 4330-87-0005). Revised to update Figures 2 and 3. Revised projected person-rem exposure for system operation and maintenance. Revised to delete references to SDS and references to the EPICOR II System for water processing.	<i>mm</i>	1/89

TABLE OF CONTENTS

<u>SUBJECT</u>	<u>PAGE</u>
1.0 PURPOSE, SCOPE, and ORGANIZATION	5.0
1.1 Purpose	5.0
1.2 Scope	5.0
1.3 Organization	5.0
2.0 DESCRIPTION OF THE SEDIMENT TRANSFER AND PROCESSING SYSTEMS	5.0
2.1 Background	5.0
2.2 Process Description	6.0
2.3 System Description	13.0
3.0 RADIOLOGICAL CONSIDERATIONS	23.0
3.1 ALARA Considerations	23.0
3.2 Contamination In Work Access Areas	23.0
3.3 Radiation Monitoring	24.0
3.4 Shielding	24.0
4.0 SAFETY	25.0
4.1 Interface to Existing Piping	25.0
4.2 Criticality	28.0
4.3 Inadvertent Liquid Release in the Auxillary Building or Reactor Building	28.0
5.0 SUMMARY AND CONCLUSIONS OF THE 10 CFR 50.59 EVALUATION	36.0
6.0 ENVIRONMENTAL ASSESSMENT	38.0
7.0 REFERENCES	39.0

Acronyms and Abbreviations

ABS	Auxiliary Building Sump
ABST	Auxiliary Building Sump Tank
AFHB	Auxiliary & Fuel Handling Buildings
ALARA	As Low As Reasonably Achievable
BNL	Battelle Pacific Northwest Laboratories
B&W	Babcock & Wilcox
CFR	Code of Federal Regulations
CI	Curie
DPW	Decon Processed Water
DW	Deminerlized Water
EPRI	Electric Power Research Institute
ft ³	cubic feet
gal	gallon
gpm	gallons per minute
GPU	General Public Utilities
HIC	High Integrity Container
hr	hour
IA	Instrument Air
l	liter
mCi	millicurie
ml	milliliter
nCi	nanocurie
R	Roentgen
radwaste	radioactive waste
SA	Service Air
SRST	Spent Resin Storage Tank
STS	Sediment Transfer System
TDW	Temporary Decon Water
TMI-2	Three Mile Island, Unit 2
TRU	transuranic
u	micron
uCi	microcurie
WDL	Waste Disposal Liquid
WDS	Waste Disposal Solid
yr	year

1.0 PURPOSE, SCOPE AND ORGANIZATION

1.1 Purpose

The purpose of this Safety Evaluation Report is to demonstrate that the evolutions which comprise the collection, transfer of sediment from tanks, and treatment of sediment in the TMI-2 Auxiliary and Fuel Handling Buildings (AFHB) and the Reactor Building basement and sump can be accomplished without presenting undue risks to the health and safety of the public.

The objective of the sediment transfer and processing program is to provide engineering design and equipment to remove any residual sediment and liquids from major tanks, sumps, and reactor building basement.

1.2 Scope

As a result of the 1979 accident, radioactive water and core debris particles were released to the Reactor Building and AFHB in various tanks, sumps, and on the reactor building basement floor. Consequently, radioactive sediment is located in these areas which consists primarily of river water sediment, concrete dust, and dirt.

The scope of this evaluation includes the collection of sediment from sumps and tanks in the AFHB, Reactor Building basement and sump, and transfer to the Spent Resin Storage Tanks (SRSTs) for processing and delivery of concentrated solids to a disposal container for cement solidification. The solidification process is not in the scope of this SER.

1.3 Organization

Section 2.0 contains a description of the sediment transfer and processing operations as well as a system description.

Section 3.0 describes the radiological considerations including the expected radiation dose rates and engineered features designed to keep exposures As Low As Reasonably Achievable (ALARA).

Section 4.0 addresses the safety issues and the design features of the system.

Section 5.0 presents the summary and conclusions of the 10 CFR 50.59 evaluation.

Section 6.0 presents the references.

2.0 DESCRIPTION OF THE SEDIMENT TRANSFER SYSTEM

2.1 Background

The 1979 accident and subsequent contamination of the AFHB and Reactor Building resulted in the generation of approximately 6700 gallons of wet radioactive sediment located throughout various

tanks, sumps, and reactor building basement. A listing of sediment locations and estimated quantities is given in Table 1. This sediment consists primarily of river sediment, and concrete dust, and dirt. This sediment presents unique problems for collection, processing, and ultimate disposal. The sediment must be processed to ensure a stable waste form in compliance with disposal site requirements and 10CFR61. At the same time, it should occupy minimum volume to conserve space at the disposal site and minimize the cost of shipping.

2.2 Process Description

During the processing of sediment transferred from any AFHB or Reactor Building source to either SRST, samples may be obtained and analyzed. The samples are analyzed to determine radionuclide concentrations for compliance with 10CFR61 criteria. Effective hydrogen ion concentration (pH), which can subsequently be controlled by the addition of lime, is also determined. Controlling the pH of the sediment increases the effectiveness of possible ferric sulfate solution addition in order to promote flocculent formation and particle settling characteristics in the SRSTs.

Upon selection of a source of AFHB sediment, the appropriate valving is aligned, and the Sediment Transfer Pump lined up to fill the selected SRST. Simplified processing and transfer Plant and Instrument Diagrams (P&IDs) are shown in Figures 1 & 2. Sediment may be removed from each source tank using a vacuum head accessed through the tank manway penetration. Also deployed through this penetration is a 3-D type nozzle powered by processed or demin water which is used to provide agitation of the sediment deposits, permitting effective collection of the solids. This nozzle is also used to flush the tank internals after removal of the major sediment deposits.

The Reactor Building basement sediment is vacuumed using a modified rover robot. The robot operates a vacuum tool which discharges the vacuumed sediment into the reactor building sediment transfer skid. The reactor building sediment transfer skid consists of a mounted 300 gallon surge tank, redundant centrifugal slurry pumps, and continuous level indication at the control panel. Basement sediment is pumped from the reactor building sediment transfer skid to the Auxiliary Building and transferred directly into the SRST for processing. Reactor Building sump sediment is capable of being removed via existing pumps and lines and discharged directly to the Auxiliary Building Sump Tanks (ABST), where it may be transferred to the SRST by the Sediment Transfer System (STS) during normal tank sediment removal operations.

During AFHB sediment transfer, the sediment transfer pump discharges sediment slurries in their unprocessed form to a common flexible hose fill line for both of the SRSTs. Whereas, the reactor building basement sediment is pumped by reactor building sediment skid to either SRST hose fill line. During sediment transfer, only one of the two SRST's is on line for sediment fill with the other on standby.

TABLE 1

ESTIMATED SLUDGE VOLUME BY SOURCE LOCATIONS

WASTE SOURCE	(a) TOTAL VOLUME (GALLONS)	(a) EST. LBS. OF WET SLUDGE AT 1.6 G/ML	(a) EST. GALLONS OF WET SLUDGE AT 7.48 GAL/FT ³	(b) EST. LBS. VOLUME (FT ³) AT 100 LBS/FT ³	(b) EST. LBS. WET SLUDGE AT 1.16 G/ML	(b) EST. GALLONS Dry SLUDGE	(b) EST. GAL. WET SLUDGE AT 5 WT. %
Reactor Coolant Bleed Tanks							
WDL-T-1A	74,850	5,500	411	55	3,981	1,712	4,050
WDL-T-1B	74,850	5,500	411	55	3,981	1,712	4,050
WDL-T-1C	74,850	5,500	411	55	3,981	1,712	4,050
Aux. Hldg. Sump Tank							
WDL-T-5	3,085	700	52	7	507	218	516
Neutralizer Tanks							
WDL-T-8A	8,780	2,400	179	24	1,737	747	1,766
WDL-T-8B	8,780	2,400	179	24	1,737	747	1,766
Make-up Tank							
WDL-T-2	4,500	1,300	97	13	941	405	958
Miscellaneous Waste Hold-up Tank							
WDL-T-2	19,800	1,600	120	16	1,158	498	1,177
Concentrated Waste Storage Tank							
WDS-T-2	9,646	2,400	179	24	1,737	747	1,766
Contaminated Drain Tank							
WDL-T-11A	2,660	610	46	6.1	442	190	449
WDL-T-11B	2,660	610	46	6.1	442	190	449
Reactor Building Basement	N/A	51,000(d)	3,815	510	36,720	15,790	37,865
Reactor Building Sump	2,722	1,400(c)	105	14	1,013	436	1,031
Auxiliary Building Sump	11,000	9,000	673	90	6,514	2,801	6,622
TOTALS		89,920	6,724	899	64,891	27,905	66,515

a. Technical Plan "Radioactive Sludge Processing" TPO/TMI-084, December 1983.

b. IOM - W. C. Lattin to T. E. Morris, "Sludge Settling/Mixing Tests," 4341-85-036, May 3, 1985.

c. Assuming a 3" sludge level in sump bottom.

d. Revised estimate from November 1984 video tapes.

Liquid levels in the AFHB source tanks and the SRST are monitored to ensure operations of the appropriate range for continuous sediment transfer. The Sediment Transfer Pump is operated for a specified period of time which is determined during startup testing. Radiation surveys are performed as necessary to determine completion of the batch transfer. Automatic liquid level control of the system is used when necessary to ensure worker radiation exposure limits are not exceeded. The mass flow rate of the liquid/sediment is monitored using a mass flow meter to determine the solids concentration during a sediment transfer. After transfer of the solids is completed, the system is lined up to flush the lines from the source tank to the SRST with Decon Processed Water. Finally, the connection at the transfer pump is lined up to backflush the remaining sections back into the source tank. Upon completion of normal transfer operations for each source tank, the hoses are drained and disconnected as necessary to align the flowpath for the next source of sediment.

The sedimentation process starts as the liquid/solids slurry is pumped into the SRST (WDS-T-1A or B). The solids would eventually settle to the bottom of the tank, but laboratory studies show that in some cases the settling rate is greatly accelerated using flocculating agents, which cause any suspended material to aggregate into a flocculent mass. As a result, the capability to add flocculating agents to the SRSTs is provided by the Chemical Addition subsystem.

The slurry is transferred into the tank through the 1-1/2" inlet connection installed in the modified manway cover. The tank is filled to a level approximately six feet below the manway cover, corresponding to approximately 2400 gallons. Filling above that level may interfere with the operation of the tank washer nozzle. The sediment concentration is measured using the transfer header mass flow flowmeter and pH is measured using existing plant methods.

Following the initial SRST fill, the sediment slurry is pumped through the recirculation piping a sufficient number of times (three tank volumes recommended) to assure proper mixing and homogeneity. In order to minimize the likelihood of flow blockages during recirculation, the SRST discharge piping has been modified to accommodate the installation of an in-line slurry conditioner known as a "delumper," which serves to chop, shred, and deagglomerate particles larger than 7/32 inch.

The original recirc line sample connection point (through valves WDS-V-24 and WDS-V-81) is not used. Instead, sampling occurs by use of an improved (i.e., shorter length and less stagnant volume) recirculation path connection point (through valves WDS-FV-116 and WDS-FV-117). The end of this sampling station protrudes through lead shielding in the spent resin transfer pump cubicle (AX010), helping to maintain radiation exposure received during sampling activities ALARA. Upon completion of slurry recirculation, the chemical conditioners may be added through a hose tie-in to the sediment fill line which penetrates the tank manway cover.

The amount of chemicals which may be added is a direct function of the amount of sediment in the tank and the pH of the mixture. Based on early laboratory results, the recommended proportions by weight to dry solids in the slurry are 2% for ferric sulfate and 3% for lime. The preferred algorithm for determining addition of chemical conditioners is based on sample results which yields the specific gravity of the dry solids and measurements of slurry mass, slurry density, slurry volume, and supernate density. The chemicals may be pumped to the appropriate SRST while the SRST mixer remains running to aid in mixing the chemicals.

Following any chemical addition and termination of mixer operation, the sediment slurry is allowed to settle before commencing decant operations. The decanting process begins with lowering the solids level detector into the tank. The decant hose, which also has an associated solids concentration detector, is then lowered into the tank to a preprogrammed concentration of suspended solids. Based on the premise that sediment solid particles are denser than the supernatant liquid, the decant hose solids concentration detector is set to a lower concentration than that found at the solid/liquid interface. This assures that the decant hose suction level is above the solid-liquid interface, thus minimizing solids pickup in the decanted supernate.

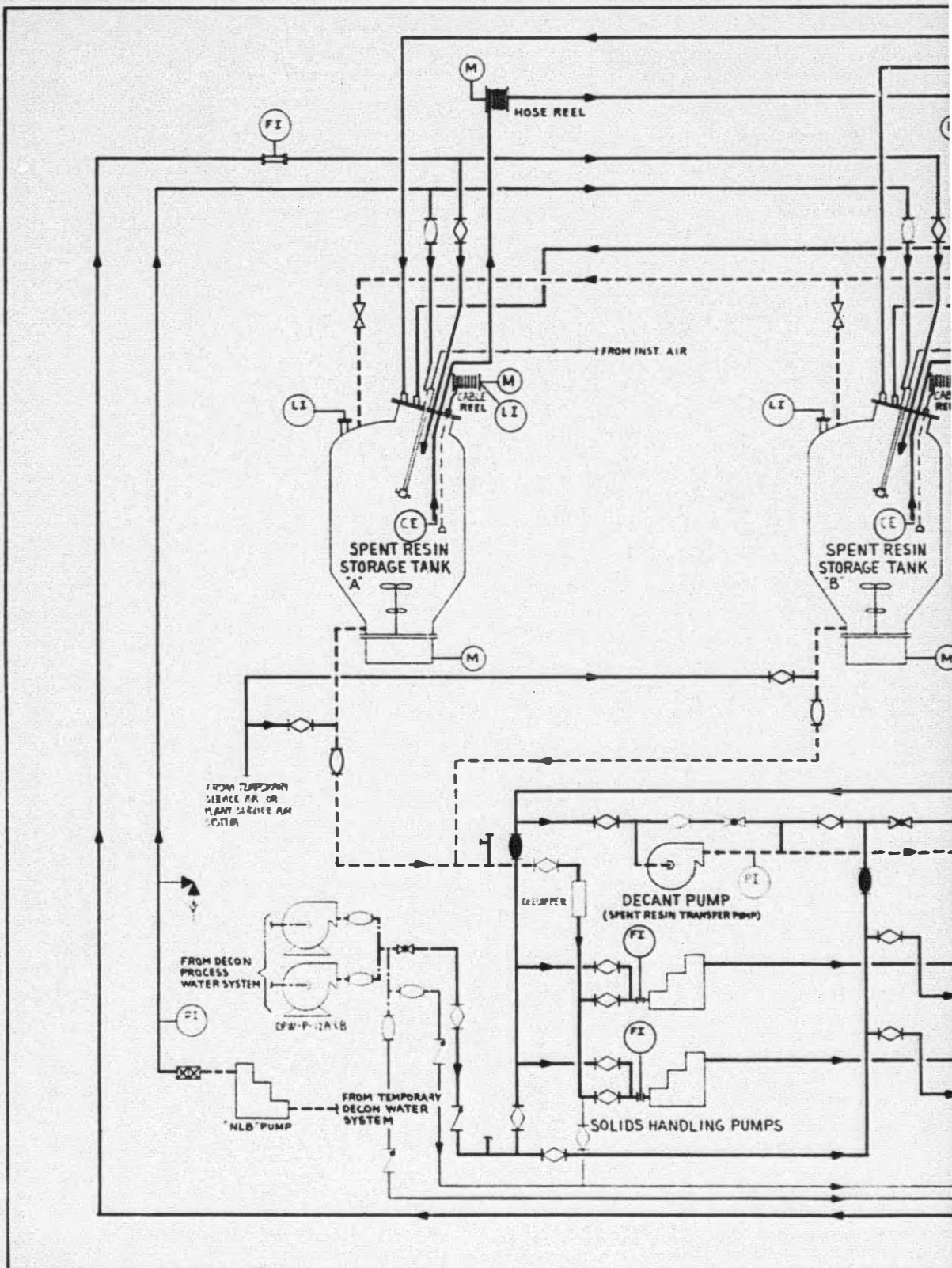

4340-3233-85-0088

FIGURE 2

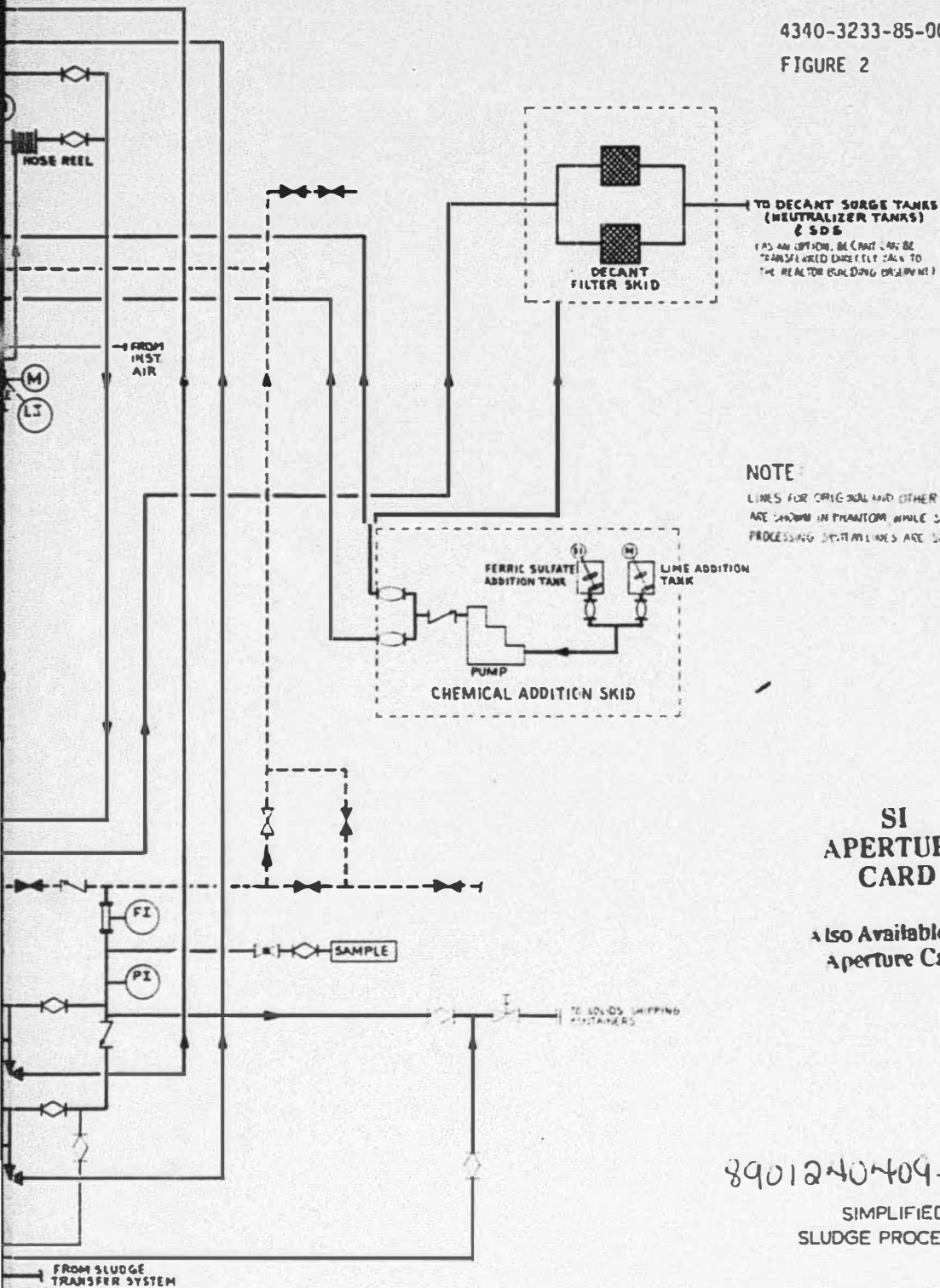

TO DECANT SURGE TANKS
(NEUTRALIZER TANKS)
& SDS
[AS AN OPTION, BE (PART) OR BE
TRANSFERRED DIRECTLY TO
THE REACTOR BUILDING OR A UNIT]

NOTE

LINKS FOR ORIGINAL AND OTHER RECOVERY SYSTEMS
ARE SHOWN IN PHANTOM WHILE STORAGE TRANSFER AND
PROCESSING SYSTEMS ARE SHOWN SOLID

**SI
APERTURE
CARD**

Also Available On
Aperture Card

8901240409-01

SIMPLIFIED P&ID FOR
SLUDGE PROCESSING SYSTEM

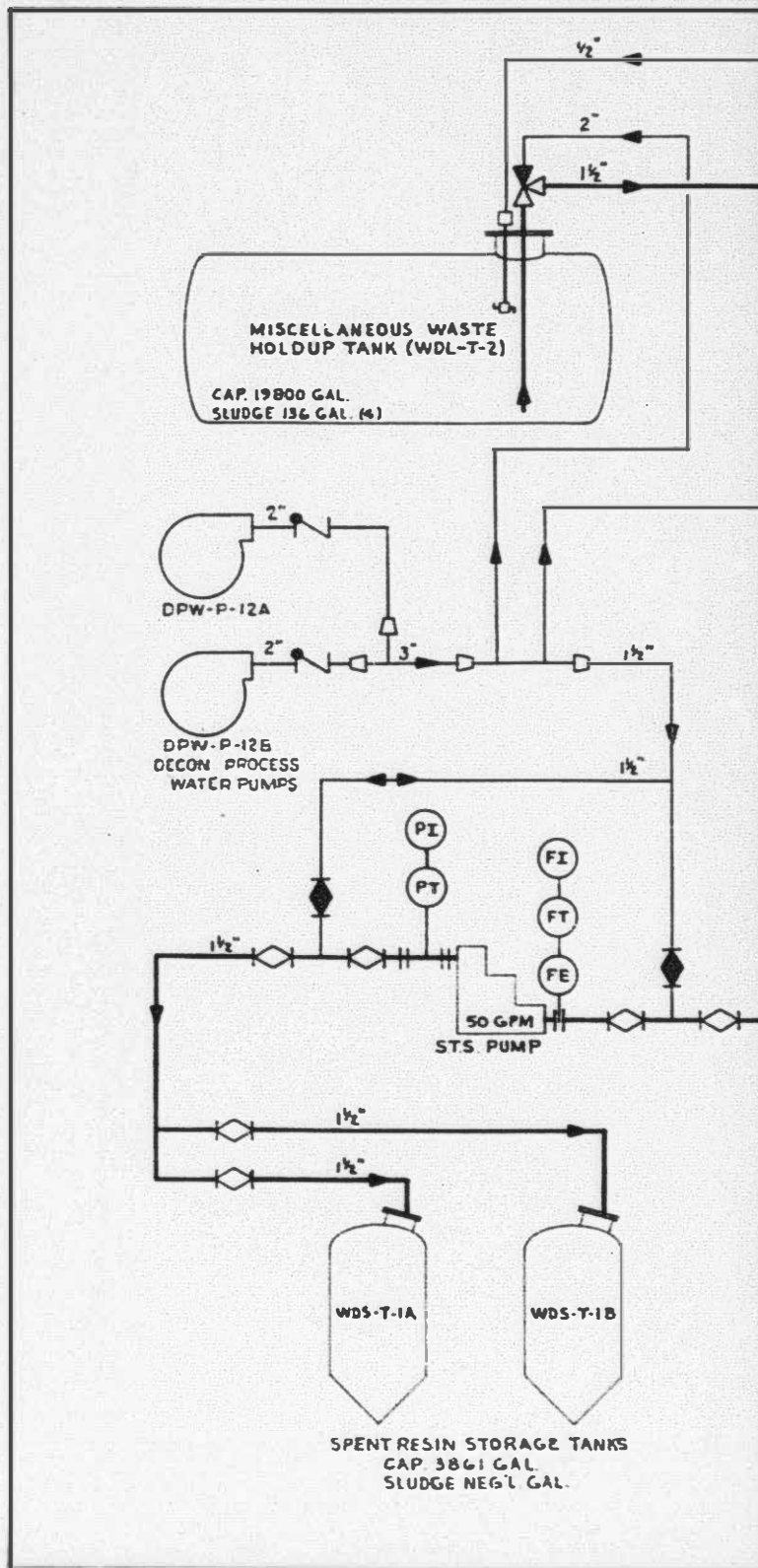

NOTES:

1. SYSTEM WILL HAVE BACKFLUSH CAPABILITY.
2. SYSTEM COMPONENTS ARE SUITABLE FOR SHIELDING.
3. TANKS ARE ASME III, CLASS C WITH MAXIMUM DESIGN PRESSURE OF AT LEAST 20 PSI. PRESSURE RELIEF PROTECTION PROVIDED BY TANK VENTS AND/OR MANWAY PENETRATIONS.
4. REF. TPO/TMI-084
5. REF. NL REG-0683

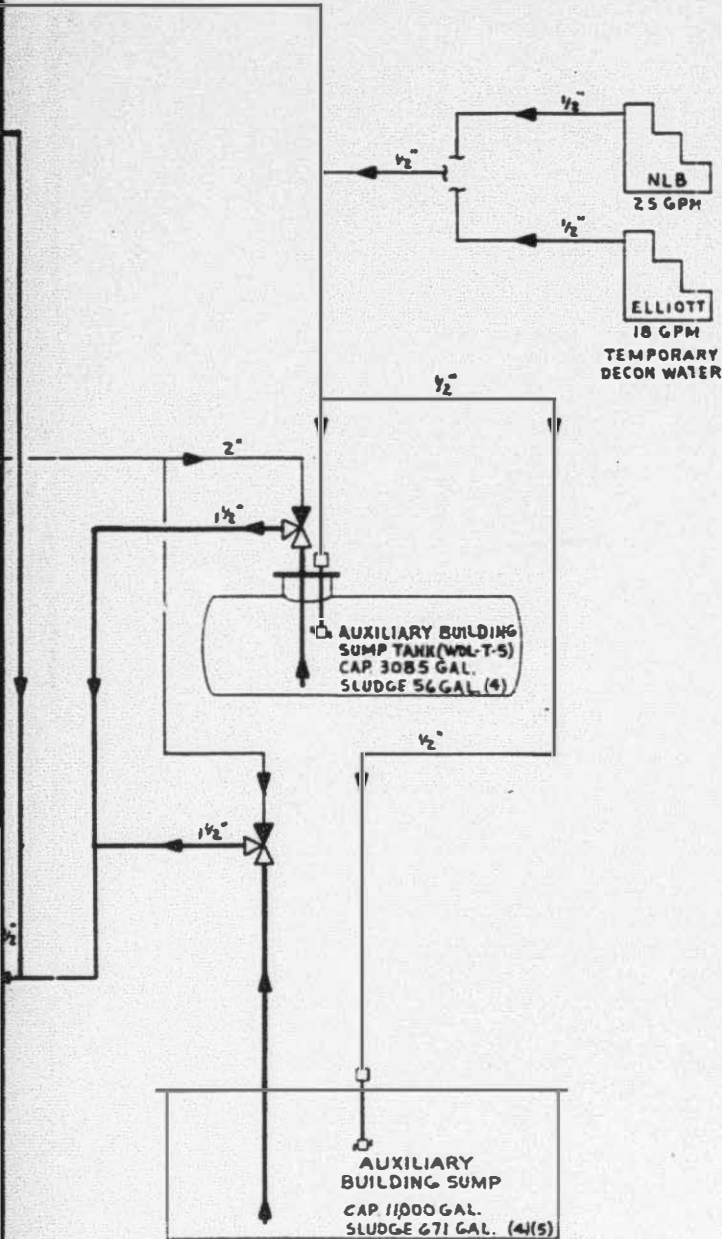

**SI
APERTURE
CARD**

Also Available On
Aperture Card

8901240409-02

FIGURE 1
SIMPLIFIED P&ID FOR
SLUDGE TRANSFER SYSTEM

The supernate is drawn into the 1" diameter flexible decant hose using the existing Spent Resin Transfer Pump (WDS-P-1) as the decant pump. The supernate is pumped at a rate of approximately 15 gpm through the decant filter skid which includes two backflushable filters in parallel, that are designed to remove all particles larger than approximately 20 microns. (Note that these filters may be chemically cleaned or precoated for improved system performance through use of the Chemical Addition Subsystem. One indicator of system performance is the differential pressure across the decant filters. Upon receipt of a high differential pressure condition, the filters are backpulsed with nitrogen and may then be backflushed with processed water). After filtration, the liquid is transferred to the Neutralizer Tanks and processed through the EPICOR II System. As an option, supernate from the processed sludge can be transferred directly to the reactor building basement without being held up in the neutralizer tanks.

Upon completion of the above decant process, a volume of concentrated sediment remains in the bottom of the SRST. Unprocessed slurry from additional sources can be transferred to the SRSTs and filled up to the 2400 gal. level, agitated as necessary, conditioned with chemicals, and the decant process repeated. This procedure may be repeated as necessary until the desired quantity of concentrated sediment is obtained. In addition, further decant operations generally result in more highly concentrated sediment slurries. Thus, solids quantity and slurry concentration can be controlled within an acceptable range for solidification and shipment.

Following decant operation(s), the concentrated sediment slurry is pumped out of the SRST(s) by the Solids Handling Pump(s), through the modified lower nozzles and discharge piping. The delumper may be run at this time to further guard against flow blockages. However, before the pumps are started, the tank discharge (pump suction) lines are flushed or backbumped to the tank bottom to dislodge any packed sediment which may block the flow.

The Solids Handling Pumps have a rated capacity of 75 gpm (corresponding to 7 fps in a 2 in. diameter pipe) with 75 psi total developed head. (Ref. 7) These pumps transport concentrated sediment from the SRSTs, through existing pump suction piping and new flexible hose, to the existing pump discharge piping. Once in the existing discharge piping, the slurry passes through a mass flowmeter which provides indication of total mass flow which is useful in loading the shipping containers. Downstream of this mass flowmeter is a branch connection for the existing system recirculation header, leading to each of the SRSTs. Upon termination of shipping container loading operations (a batch process), the excess sediment slurry can be recirculated back to the appropriate SRST, thus precluding the formation of lines filled with stagnant sediment slurry. Stagnation is undesirable due to possible buildup leading to flow blockage as well as causing localized high radiation areas.

2.3 System Description

The Sediment Transfer System, Processing System, Chemical Addition, and Decant Subsystems comprise the sediment removal program. The sediment removal program is designed to remove radioactive sediment and liquid from various tanks, sumps, and the reactor building basement floor. Implementation of these systems required modifications to original plant systems as well as the installation of new components which interface with original plant systems. The separate systems comprising the total program are described as follows:

2.3.1 Sediment Transfer System

Modifications may need to be performed on the original AFHB tanks to allow for sediment removal. (Ref. 16) The potential sediment source tanks are listed below:

- Reactor Coolant Bleed Tanks
 - HDL-T-1A
 - HDL-T-1B
 - HDL-T-1C
- Auxillary Building Sump Tank
 - HDL-T-S
- Neutralizer Tanks
 - HDL-T-8A
 - HDL-T-8B
- Make-Up Tank
 - MU-T-1
- Miscellaneous Waste Hold-Up Tank
 - HDL-T-2
- Concentrated Waste Storage Tank
 - HDS-T-2

Temporary replacement manway covers which allow for installation of tank washers, suction lines, and level detection instrumentation may be fabricated and installed on these tanks for Sediment Transfer Operations.

Similarly, to allow for sediment transfer to the Spent Resin Storage Tanks, temporary replacement manway covers (Ref. Figure 4) have been fabricated to allow for sediment fill, chemical addition, decanting, pump discharge relief valve blowdown, flushing of tank

internals, and sediment level (concentration) detectors. A typical SRST is shown in Figure 3, with original specifications listed in Table 2. The SRST's have been downgraded for the sediment transfer and processing operations to ANSI/API Std. 650, 7th Ed-1980.

To transport sediment from these sources to the processing system, a sluicing or pumping method is required. Sediment slurries with solids concentrations in the range of 1 to 5 weight percent are pumped to the SRSTs by a new Sediment Transfer Pump (STS-P-1). The Sediment Transfer Pump, which is located on the 280'-6" elevation of the Auxiliary Building, is a commercially available progressive cavity pump capable of handling the TMI-2 sediment. Transfer pump specifications are listed in Table 3.

The original plant design for delivering resins to the SRSTs is via the in-plant spent resin sluice lines. These lines are physically located too high in the Auxiliary Building to efficiently transport a concentrated sediment slurry. Additionally, these pipe lines do not serve all the sediment sources being removed during the Sediment Removal Program. Hence, flexible hoses are used to transfer sediment from various source tanks, sump and reactor building basement floor to the SRSTs.

These flexible reinforced hoses are equipped with two-way shut-off couplings, which are used to transfer the slurry between hard pipe portions at the Sediment Transfer Pump and each tank connection.

The Sediment Transfer System is capable of maintaining sufficient flow rates to prevent settling of the sediment during transfer. The layout for the transfer system is shown in Figure 1.

Additionally, the Reactor Building basement floor sediment is collected by using a remotely operated robot with attached wet vacuum system or other collecting device and discharged to the Reactor Building Sediment Transfer Skid located on the Reactor Building 305'-0" elevation. Sediment is then pumped from this skid through flexible hose to a containment penetration and discharged directly to the SRSTs.

Sediment may be pumped from the Reactor Building Sump, utilizing the original sump pumps (WDL-P-2A&B), through original piping, and discharged directly to the Auxiliary Building Sump Tank, thenceforth to the SRST via the Sediment Transfer System. In the event of a reactor building sump pump failure, removal of sediment from the sump may be performed by lowering a flexible hose through a basement floor drain to access the sump.

FIGURE 3

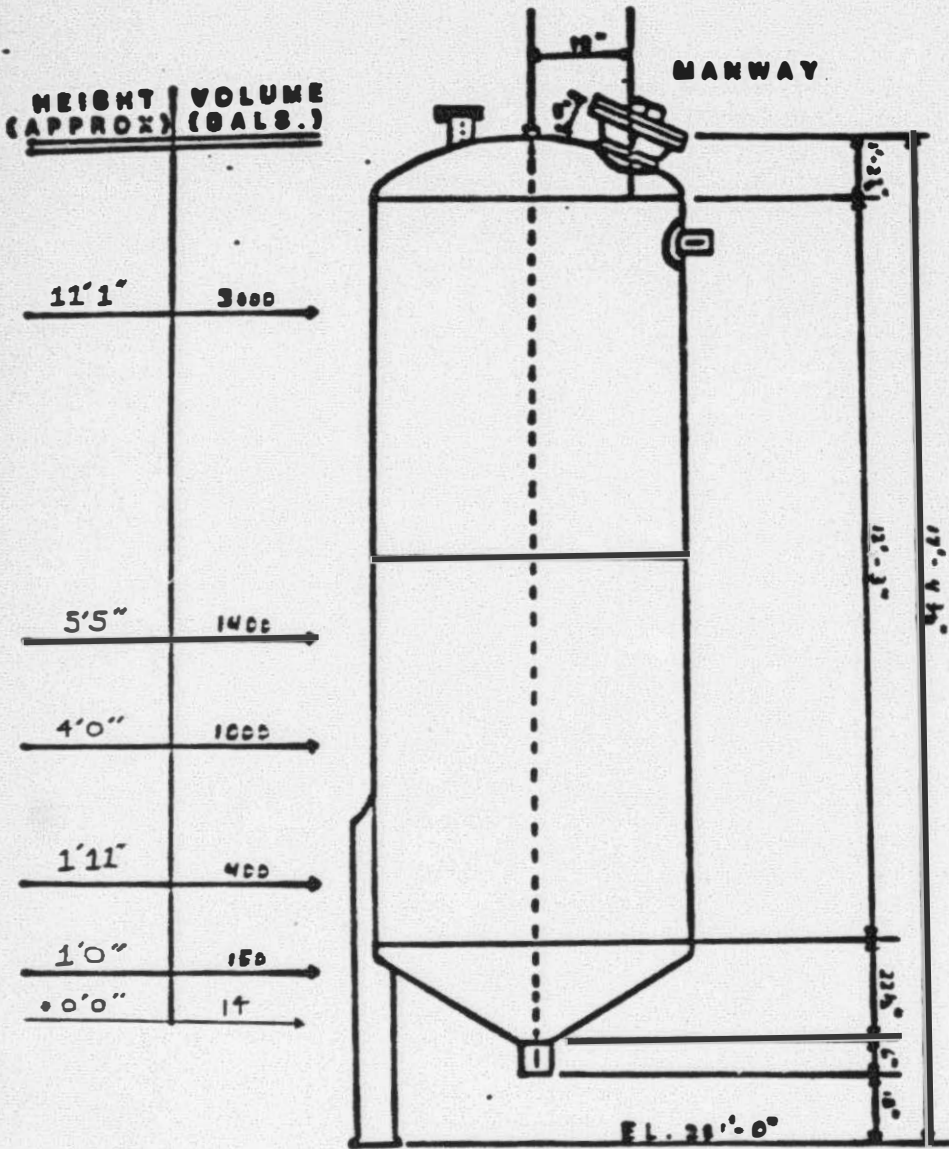

SPENT RESIN STORAGE TANK

3861 **GALLON CAPACITY**

* ZERO LEVEL 0.7' ABOVE TOP OF 6" DISCHARGE NOZZLE

TABLE 2

SPENT RESIN STORAGE TANKS

Identification	WDS-T-1A, WDS-T-1B	
Manufacturer	Richmond Engineering Co., Inc.	
Capacity, gallons	3,861/Tank (2400/Tank Normal Level)	
Capacity, cubic ft.	516/Tank (321/Tank Normal Level)	
Installation	Vertical	
Outside diameter & length	7'0"; 15'-10 3/8"	
Shell material	SA-240, 304 S/S	
Shell thickness, in.	3/8	
Design temperature, °F	150 (Ambient)	
Design pressure, psig	20 (Atmospheric)	
Corrosion allowance, in.	0	
Design Code	1968 ASME Code, Sec. III, Class "C"	(ANSI/API Std. 650, 7th. Ed - 1980)
Code Stamp required	Yes	
<u>Classification</u>	<u>Level</u>	
Code	N-3	
Quality Control	3	
Seismic	I	
Cleanliness	D	

Note: The original specifications for the SRST(s) listed in this table have been downgraded for the sediment transfer and processing system as indicated in parentheses.

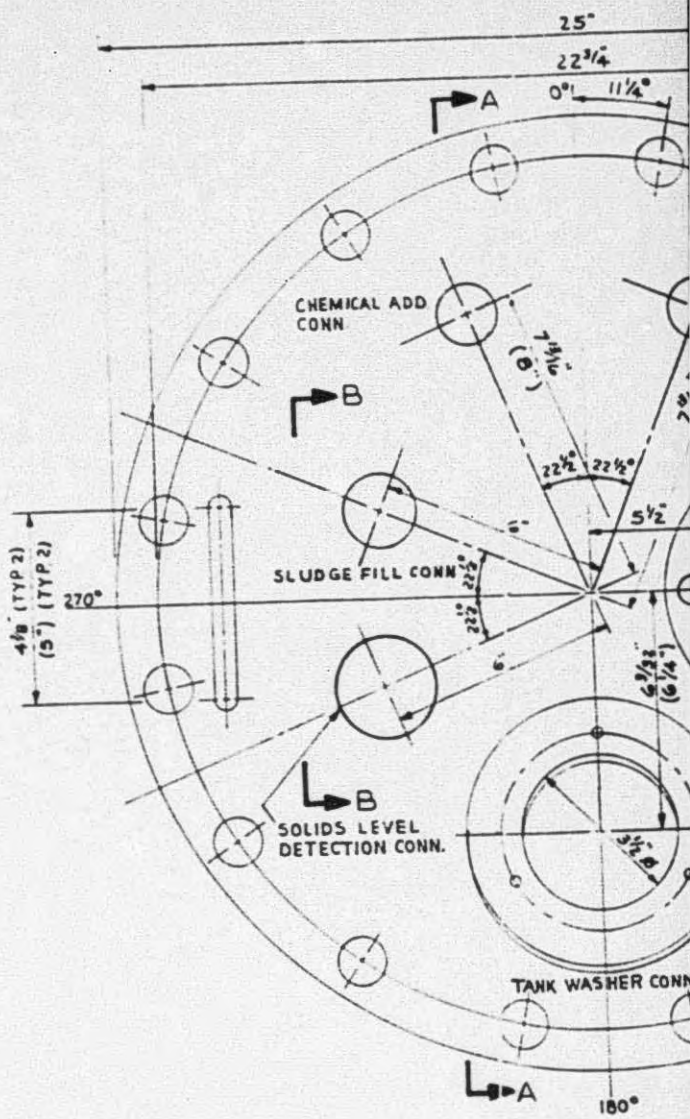

PLAN VIEW

(MS) CHEMICAL ADD CONN.
 (FS) (PSU) WDS-FRI & Z DISCH CONN.

1" SCH. 40S PIPE

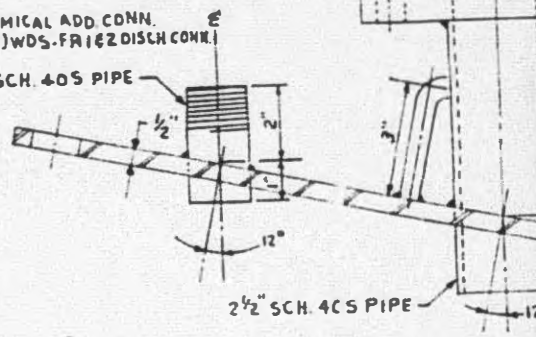

SECTION

FIGURE 6

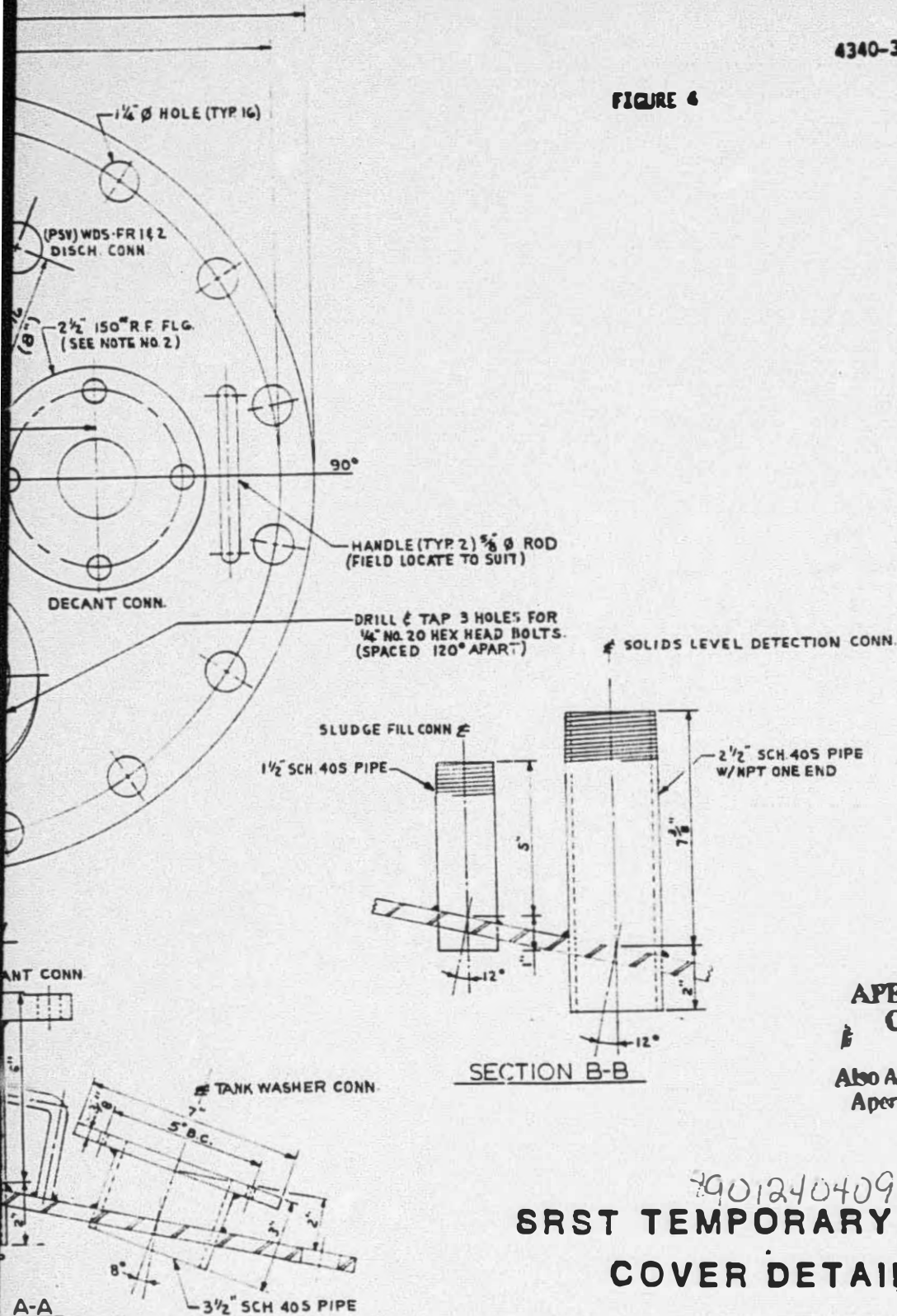

SI
APERTURE
CARD

Also Available On
Aperture Card

2901240409-03
SRST TEMPORARY MANWAY
COVER DETAILS

2.3.2 Sediment Processing System

To help maintain a homogenous slurry mixture in the SRSTs during sampling and chemical addition, the lower nozzle on each SRST has been modified to accommodate the addition of a bottom entry, dual propeller electric mixer, which projects upward into the tank and may be used to agitate its contents. Plant service air may also be introduced into the conical bottom and discharge piping of each SRST to provide an alternate form of agitation. This technique serves to clear possible blockages in the tank discharge piping better than through use of the mixers. Each original 2 inch diameter discharge line has been relocated so that its connection is on the side of the nozzle. (Ref. Figure 5)

Once all the sediment has been delivered to the SRSTs, it is processed into a concentrated form suitable for solidification in a solids shipping container. For solidification, the optimum solids concentration is in the range of 20 to 40 weight percent. This concentrated sediment slurry will be transported from the SRSTs to a solidification system. The final weight percent of this slurry will be determined by the waste classification and allowed curie content (nCi/gm) of the final waste form.

The original Spent Resin Transfer Pump is a centrifugal type pump, which is not suitable for transporting a concentrated slurry mixture. Therefore, the existing SRST discharge piping has been modified to provide for the addition of two redundant Solids Handling Pumps (WDS-FP-2A&B) which discharge to either the SRST recirculation header for mixing and sampling or a waste shipping container. These pumps are positive displacement progressive cavity type, capable of transporting slurries with a wide range of solids concentrations. (Pump details are listed in Table 3). Additional discharge piping modifications have been performed to provide for processed water reverse flow or backbumping of the SRST bottom nozzles and discharge piping. The Solids Handling Pumps may also be operated for short durations in reverse mode to assist in reversing flow and clearing line blockages. Pump motor currents are monitored during reverse operations. Hoses are inspected for leakage following reverse mode operations.

2.3.2.1 Chemical Addition

Sediment concentration is achieved through solids settling in the SRST followed by dewatering or decanting operations. A Chemical Addition Skid is located on the 280'-6" elevation of the Auxillary Building and may be used to add chemical conditioners to the SRSTs to accelerate the sediment settling rate. The skid

consists of two 60 gallon open tanks (one each for ferric sulfate - $\text{Fe}_2(\text{SO}_4)_3$ and lime $\text{Ca}(\text{OH})_2$ solutions), one mixer in each tank, one rotary flexible-liner type positive displacement pump, along with associated piping, valves, and local controls. The skid is portable, does not tie in permanently to any existing plant system, and except for the decon processed water used to mix chemicals, will not handle radioactive material.

TABLE 3

<u>Pump Details</u>	<u>Sediment Transfer Pump</u>	<u>Solids Handling Pumps</u>
Identification	STS-P-1	WDS-FP-2A&B
Manufacturer	Robbins & Myers (Moyno Pump Division)	Robbins & Myers (Moyno Pump Division)
Model No.	Centennial Line 2EOFS1-SSQ-DAA	Centennial Line 2FOGS1-SSQ-DAA
Type	2-stage, horizontal, progressive cavity	2-stage, horizontal, progressive cavity
Rated speed, rpm	282	230
Rated capacity, gpm	50	75
Rated total developed head, feet water	173	173
Shaft seal	Double mechanical	Double mechanical
Lubricant	Water	Water
<u>Motor Details</u>		
Manufacturer	Rellance	Rellance
Type	Induction	Induction
Enclosure	TEFC	TEFC
Rated horsepower, hp	7.5	7.5
Speed, rpm	1800	900
Insulation class	B	B
Service	Continuous duty	Continuous duty
Service factor	1.15	1.15
Lubricant/coolant	Grease, air	Grease, air
Power requirements	460v, 3 phase, 60 Hz	460V, 3 phase, 60 Hz

FIGURE 5

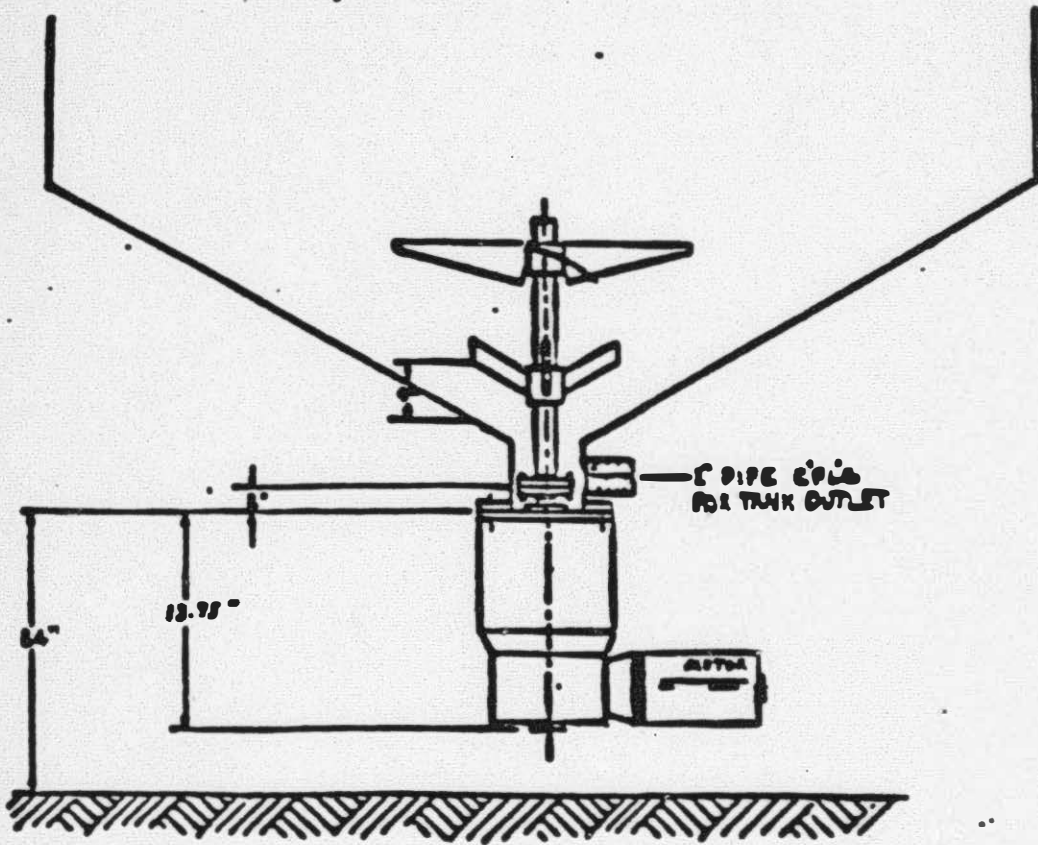

**SRST LOWER NOZZLE
MODIFICATIONS**

2.3.2.2 Decant Operations

The Decant System is designed to decant the supernatant liquid from the concentrated sediment in the SRSTs, pump the liquid to a filter skid, and from there to a neutralizer tank. As an option, supernate from the processed sludge can be transferred directly back to the reactor building basement without being held up in the neutralizer tanks. The filter skid used in the decant operations is the same filter system used for rinse and elution of makeup and purification demineralizer resins. (Ref. 27) Ultimately, this water is transferred to the EPICOR II System for processing. The liquid from either SRST is removed by lowering a decant hose into the tank through its manway opening. A motorized hose reel is used to lower this hose to a level determined by the suspended solids detectors. The original Spent Resin Transfer Pump (HDS-P-1) delivers the decanted liquid to the filter skid, and then to either of the Neutralizer Tanks (HDL-T-8A&B), at a flowrate of 15 gpm. From these tanks, the decant is finally delivered to the EPICOR II System by a Neutralizer Tank Pump(s) (HDL-P-8A&B) at approximately 5-15 gpm utilizing standard operating procedures. As previously mentioned, decant from reactor building processed sludge can be transferred from a SRST directly back to the reactor building basement without being staged in the neutralizer tanks.

2.3.2.3 Flush Operations

Decon Processed Water (DPW) is used to flush the Sediment Transfer Pump and lines, source tanks, SRST bottom nozzle, discharge lines and Solids Handling Pumps. Decon Processed Water Pumps (DPW-P-12A&B) provide flush water through hose connections at the Sediment Transfer Pump and at each source tank. Post-sediment transfer flush can be performed from these connections in forward and backflush flowpaths. In addition, DPW is supplied for backflushing the SRST bottom nozzle area as well as for forward and backflushing capabilities of the discharge lines and solids handling pumps. This minimizes any residual buildup and potential hot spots.

Existing high pressure positive displacement pumps (Elliott/NLB) in the Temporary Decon Water System provide approved decon water to a NLB 3-D nozzle mounted in the temporary replacement manway cover on each source tank and SRST washers. The nozzle arms rotate in a vertical plane and drive the body of the nozzle in a horizontal plane, thus providing a 360 degree spherical spray pattern. The source tank nozzle can be positioned to sweep solids to the vacuum head for pickup and for tank wall washdown. Whereas the SRST nozzle provides for tank internal washdown and water addition for possible dilution of sediment slurries.

3.0 RADIOLOGICAL CONSIDERATIONS

3.1 ALARA Considerations

All personnel performing work within the bounds of this evaluation utilize every means available to maintain their exposures to radiation as low as reasonably achievable (ALARA). Radiological Controls personnel monitor work areas as required and provide dose rate information to aid individuals in performance of their tasks in so far as radiological work practices are concerned.

Extensive planning of tasks to be conducted in radiation areas and training of personnel are used to reduce the time necessary to complete tasks. Mockups for training and proof-of-principle testing are also used. Higher radiation areas are identified to personnel and shielded where practical. Work is structured to avoid those areas to the extent possible.

Currently, the assembly, installation, and operation of the sediment transfer and processing system have resulted in personnel exposure of approximately 44 person-rem. The projected expenditure for continued operation of the sediment transfer and processing system is estimated to be approximately 58 person-rem.

3.2 Existing Contamination in Working Access Areas

Worker accessibility for the removal of sediment from sumps and tanks may be required in the following cubicles:

AX021-	Reactor Coolant Bleed Tank A
AX020-	Reactor Coolant Bleed Tanks B & C
AX012-	Auxiliary Building Sump and Sump Tank
FH009-	Neutralizer Tanks
AX116-	Makeup Tank
AX131-	Miscellaneous Waste Holdup Tank
AX218-	Concentrated Waste Storage Tank
AX501/502-	Reactor Building Spray Vaults
AX503/504-	Decay Heat Removal Vaults

Each AFHB cubicle will be decontaminated to remove contamination hot spots, to minimize the need for respirators and to reduce general area dose rates as specified in the Phase III endpoint criteria (Ref. 19). Respirators may still be necessary for tank sediment removal operations due to the potential for induced airborne radioactivity caused by spraying and mixing operations. Any respirator requirements will be stipulated by Radiological Engineering. The potential sediment source tank temporary manway covers are designed to seal and secure each tank to minimize the possibility of airborne leakage. In addition, the SRST manways have been fitted with a vented plexiglass box enclosure to further minimize the potential for airborne release. Auxiliary building airborne activity is continuously monitored by existing air monitoring systems.

3.3 Radiation Monitoring

Portable radiation monitors are used in detecting radiation levels in general work areas. The monitors are located near potential sources of radiation and in areas where a buildup of radioactive material may result in excessively high radiation levels. As determined by Radiological Engineering, airborne monitoring of the spent resin transfer pump cubicle (AX010) and Auxiliary Building basement hallway take place during system activities.

3.4 Shielding and Access Control

The primary objective of shielding design and access control is to protect operating personnel and plant personnel from radiation sources in the Auxiliary Building, including the sediment transfer header, transfer pumps, Spent Resin Storage Tanks and the concentrated slurry transfer hose. Corridors have been shielded to maintain dose rates at ≤ 2.5 mrem/hr during normal sediment transfer operations.

Shielding design in the Auxiliary Building is based on the shielding of process equipment, resin tanks and the transfer of spent resins and solidified waste. The transfer and processing system design incorporates provisions to preclude the formation of stagnant sediment slurry zones, which include interconnected flowpaths and use of flushwater. Therefore, localized piping hot spots are minimized. The concrete walls of the SRST cubicles were originally designed to allow a maximum of 2.5 mrem/hr in adjacent areas while processing spent resins. Design radioactivity levels are based upon 1% leakage of fission products from the fuel rods. Since the total activity in the sediment to be processed is less than the design case, radiation levels in adjacent areas due to sediment contained in the tanks is not expected to be greater than 2.5 mR/hr. Calculations made using the ISOSHL computer code confirm the dose rates to be much less than 0.01 mR/hr.

The bottoms of the SRSTs may be shielded inside their respective cubicle (AX008, AX009) to allow for maintenance of the mixers. Shielding should consist of lead blankets or lead sheets and cover the lower nozzle and discharge piping. The amount of shielding required should be minor since the tank will be empty and flushed if necessary to reduce the dose rate prior to performing any maintenance inside the cubicle.

The sediment transfer manifold and hoses have been shielded to maintain general area radiation levels at or below 2.5 mR/hr during normal transfer operations. The hose from AFHB sediment sources to the SRST should result in about 54 mR/hr (unshielded) at a one-foot distance with 5% by weight sediment in the line. The installed shielding (lead bricks) reduces that to ≤ 2.5 mR/hr.

Hoses from the SRST to the solidification feed station, however, may result in up to 2 R/hr at one foot. The transfer pump skid has been shielded to maintain workstation radiation levels at or below 2.5 mR/hr. Process flow valves which require operation have been located behind shielding and provided with reach rods or remote operators. The hoses from the chemical addition skid are not shielded since no radioactivity exists in these lines.

The discharge transfer hose from the reactor building basement sediment removal skid has been routed on the 305 ft elevation to a designated reactor building penetration for transfer to the SRST. The hose from the reactor building basement to the SRST may result in about 200 mR/hr (unshielded) at a one-foot distance with 5% sediment in the line. The transfer hose has been shielded to reduce hot spots and to minimize any contribution to general area dose. Shielding design and desired dose reduction is determined by Radiological Engineering.

4.0 SAFETY

To accomplish sediment transfer and processing tasks safely and effectively, process pathways have been chosen which minimize impact on other plant operations. This section describes all of the parameters and postulated accident scenarios which have been accounted for in the design of the system.

4.1 Interfaces with Existing Piping

To incorporate the system hardware into the process there are several tie-in points at which new piping has been connected to existing plant systems. The Sediment Transfer and Processing System interface with the following temporary and permanent plant systems:

1. Waste Disposal Liquid (WDL) System

The sediment removal connections to the WDL System are via temporary replacement manway covers for the source tanks (Neutralizer, Miscellaneous Waste Hold-Up, Contaminated Drain, Auxiliary Building Sump, and Reactor Coolant Bleed Hold-Up Tanks), and by lowering a vacuum wand into the Auxiliary Building Sump. The effluent from decant operations passes through the WDL System (Neutralizer Tanks) and ultimately to the EPICOR II System. Whereas, during transfer directly back to the reactor building basement, the effluent from decant does not pass through the WDL system. The sediment transfer system does not directly interact with the EPICOR II, and ties in only via the WDL system.

2. Waste Disposal Solid (WDS) System

The sediment removal connections to the WDS System are via temporary replacement manway covers for the source tank (Concentrated Waste Storage Tank) and for the processing tanks (Spent Resin Storage Tanks). In addition, the WDS System

pipng has been modified as described earlier. The connection with existing plant piping can be seen on the system drawing, 2E-3233-1035. (Ref. 21)

3. Temporary Decon Water (TDW) System

The TDW System involves use of the National Liquid Blasting (NLB) Pump to supply the SRST and sediment source tank washers. The Elliott Speedblast Waterblaster High Pressure (Elliott #2) Pump also uses TDW for sediment source tank washers. In order for the TDW system to become contaminated, sediment would have to rise above its normal level (or alarm point), enter the washer nozzle, travel up the washer shaft, back through the supply line, and up to 305' elevation to the source pump. In the case of SRST washers, additional isolating valves must be bypassed. The probability of occurrence for each of these events is considered remote. In addition, the driving heads are not considered to be sufficient for reverse flow. Thus, single barrier isolation in this case is considered adequate.

4. Decon Processed Water (DPW) System

The DPH System involves use of pumps DPH-P-12A and B to supply flush water for the sediment source tanks, Sludge Transfer Pump Skid, SRSTs, Chemical Addition Skid, Decant Filter Skid, Reactor Building Sludge Transfer Skid, and associated lines. DPH is also used to supply the accumulators associated with the double mechanical seals for the SRST mixers, solids handling pumps, sludge transfer pump and solids handling delumper. System components are flushed with DPH as necessary to remove solids deposits and/or radiation levels. Chemical mixing operations may utilize either or both of the sixty gallon Chemical Addition Tanks and a minimal quantity of DPH. DPH is automatically introduced to the system equipment seal accumulators upon supply header pressure dropping below 30±5 psig. Based on normal weepage across the seal faces, a minimal quantity of DPH makeup is required. (Note that the DPH supply line contains a check valve to prevent backflow of demineralized water when the DPH System is depressurized.)

5. Demineralizer Water (DW) System

Demineralized water is used as a backup to the decon processed water supply for the double mechanical seals associated with the SRST mixers, solids handling pumps, sludge transfer pump and solids handling delumper. DW is automatically introduced upon seal water supply pressure dropping below 25±5 psig. Based on proper maintenance of the seals, a minimal quantity of demineralized water is required. (Note that the DW supply line contains a check valve to prevent backflow of decon processed water when the DW System is depressurized.)

6. Instrument Air (IA) System

Instrument air is used for actuators on automatic valves as well as for SRST washer air motors in the Sludge Transfer and Processing System. Minimal quantities of air are consumed with each valve movement. Instrument air supply to each SRST washer motor determines the time required for a complete washing cycle. It does not affect water spray. A minimal quantity of IA is required for tank washing.

7. Service Air (SA) System

Service air is used for actuators on automatic valves on the Reactor Building Sludge Removal Skid and for sparging of the SRSTs. Minimal quantities are consumed with each valve movement. Minimal quantities of service air from either the plant Service Air System or a temporary compressor will be used to blow through the SRST discharge lines and conical bottoms to clear any blockages prior to transfers from these tanks. Check valves and administrative control of hoses help prevent back contamination of the SA System from SRST sparging activities.

8. Nitrogen System

Separate from the permanent plant nitrogen systems, bottled nitrogen is used to increase the backpressure on the buffer fluid for seals associated with the solids handling and sludge transfer pumps as well as solids handling delumper during flushing modes. Buffer fluid pressure must exceed process fluid pressure otherwise leakage will not be out of, but into, the seals and process fluid line integrity will be lost.

9. Electric Power and Control Supplies

Two types of original plant power are used in the Sludge Transfer and Processing System. Nominal 480 VAC power is used for the multiple phase, larger horsepower motors associated with the sludge transfer, solids handling, Reactor Building sludge pumps, the SRST mixers, the Reactor Building sludge tank mixer, and the solids handling delumper. Nominal 120 VAC power is used for the single phase, smaller horsepower motors associated with the chemical addition pump, chemical addition tank mixers, solids level detector cable reels, and decant hose reels. In addition, nominal 120 VAC control voltage is provided to the various instrumentation assemblies.

10. Miscellaneous Systems

The sediment removal connections to the various Auxiliary Building source tanks occur via temporary replacement manway covers. The Reactor Building Sump sediment removal will first be attempted through use of the original plant sump pumps and piping. If unsuccessful, other means may be attempted.

Testing to the extent practical prior to system operation will determine the integrity of these barriers or the need to provide additional isolation.

All process flow lines will be hydrostatically tested in accordance with ANSI B31.1 in order to guard against line breaks, valve, pump and flange leaks.

Hydrostatic testing will be performed using DPH prior to any sediment handling operations.

4.2 Criticality

Criticality will not occur during sediment processing operations assuming that the fuel estimates for the Reactor Building Sump, Reactor Building Basement Sediment, Auxiliary Building Sump Tank, and Sump represent a worse case fuel quantity scenario for all AFHB and reactor building sediment sources being processed.

The critical mass of UO_2 with three wt% U^{235} and 0.4 inch maximum pellet diameter in unborated water is 93 Kg (Ref. 18). To ensure that no criticality would occur, a conservative limit was established in which the minimum critical mass is considered to be 75% of 93 Kg. Thus, the conservative critical mass is approximately 70 Kg. The amount of fuel present in the Auxiliary Building Sump and Sump Tank was calculated based on gamma spectroscopy measurements performed by Fuel Measurements and Analysis (Ref. 15). The mass of UO_2 calculated to be in the sump is 0.265 kg and in the sump tank is 0.0014 kg, respectively. Consequently, it is concluded that an insufficient amount of fuel is contained in the Auxiliary Building Sump and Sump Tank to achieve a critical mass.

Similarly, the Reactor Building Sump criticality evaluation report concludes that fuel present could vary between 2 kg to less than 20 kg in the basement, which is an insufficient amount of fuel to achieve a critical mass (Ref. 24). Therefore, based on the above fuel estimates, combining sediment from these sources would not constitute a sufficient quantity of fuel capable of achieving a critical mass. Additionally, the SRST capacity (3861 gallons) prohibits the combining of all the sediment from these various sources.

4.3 Inadvertent Liquid Release in the Auxiliary Building or Reactor Building

Inadvertent releases of liquid from the sediment transfer or processing equipment could result from valve misalignment, hose rupture, or tank overflow. Any leakage during transfer of the Reactor Building basement liquid/sediment onto the 305' elevation of the Reactor Building would simply drain back to the basement floor and would remain within the building. Personnel exposure is minimized since Reactor Building access is controlled. No inadvertent environmental release of this water would occur. Inadvertent release scenarios in the Auxiliary Building were

contemplated without allowance for initial detection. The scenarios and their consequences are described in the sections that follow.

4.3.1 Spent Resin Storage Tank Overflow

The overflow of the SRST has been considered in the event of a postulated instrument failure and/or an operational error. Liquid levels in the SRST are continuously monitored by automatic sonic level detectors. As a result of overflow, liquid/sediment would fill the SRST and overflow through the existing 2" overflow line, to a floor drain which drains to the Auxiliary Building Sump (ABS). Other tank exit pathways are isolated during all sediment transfer operations. Since the overflow line ends one inch above the funnel shaped floor drain, a minor amount of slurry may spill onto the cubicle floor (AX008 or AX009).

Any increase in the ABS level caused by an SRST overflow would be detected at the radwaste panel digital readout, which is monitored during sediment transfer operations. No inadvertent release to the environment would occur and personnel exposure would be negligible since the ABS is in a locked, high radiation area and the SRST cubicles (AX008 and AX009) have limited access dependant on discharge dose rates during process operations.

4.3.2 Hose and Valve Leaks

Hose and/or valve leaks are possible in areas where process piping and hoses are routed. Various cubicles which are susceptible to leakage are listed in Section 3.2. Additionally, leakage could occur from hoses routed in corridors on all elevations of the AFHB. However, in each of these areas floor drains lead to the Auxiliary Building Sump. Since this type of contemplated condition has the potential to divert small quantities of liquid to the sump, (i.e., quantities small enough to go undetected by the flow rate detectors and pressure detectors noted in Section 4.3.3), it is likely that this type of leakage would be detected by an increase in sump level indication.

An increase in airborne activity would be detected by the air monitoring system. Leakage is further minimized by the use of poly bags or sleeves placed at each of the hose and valve connections. All system hose and pipe is leak tested in accordance with ANSI B31.1. Inadvertent release from the Auxiliary Building to the environment would be very minor and well within that analyzed for a spent resin storage tank rupture.

4.3.3 Transfer and Process Hose Rupture

Releases caused by a hose rupture or break in the system are minimized by monitoring and control circuits in the transfer and process systems. In the event of a hose rupture in the transfer system, a pressure detector on the discharge side of the transfer pump will sense low pressure and trip the pump. In the event of a similar break in the process system, the mass flow detector on the discharge side of the solids handling pump will detect a rate change and activate an alarm on the status and control panel, notifying the operator to secure process operations. The suction side of each of these pumps is monitored by a fluid detector which when it detects a loss of fluid, as in a hose rupture, will trip the pump.

Similarly, the transfer hose from the reactor building penetration to the SRST is protected from a system rupture by a pressure detector on the discharge side of the reactor building sediment removal pump. When a loss of pressure is detected by this instrument it will trip the sediment removal pump.

Based on the above information, an inadvertent release from a hose rupture would result in a spill of approximately 50 gallons.

It is assumed this 50 gallon spill is released in the corridor on the 280' elevation in the Auxiliary Building and half of the spill will drain to the ABS through floor drains and the other half will remain on the corridor floor. The resulting dose rate exposure at the center of the spill would be 895 mr/hr at 1 foot.

The amount of airborne released from this type of liquid spill would be very minor. Any releases of airborne activity would be within the AFHB and would be removed by the high efficiency air (HEPA) filters. Off-site airborne release would be insignificant and far within the bounds of that postulated in a SRST rupture.

4.3.4 Valve Misalignment

The closed loop configuration of the transfer and process system design virtually eliminates the possibility of a misaligned valve causing an inadvertent release of sediment slurries. The exceptions to this fact are in two valve locations in the processing system plant design. These valves are the 1/2" local sample connection valves WDS-FV-116 and WDS-FV-117 (located in cubicle AX010, Spent Resin Transfer Pump Room) and the 2" resin transfer valve WDS-V-79 (located in cubicle FH001, Reclaimed Boric Acid Pump Room). To minimize an

Inadvertent release by these valves, their operation is administratively controlled by system operational procedures.

Any release of radioactivity from a valve misalignment would be released within the containment or the AFHB. The containment or AFHB would act as a physical barrier and prevent any liquid release from escaping to the environment. Any airborne release and dose consequence is bounded by the SRST rupture accident.

4.3.5 Spent Resin Storage Tank Rupture

The possibility of an accident in the course of the sediment transfer and processing operations is remote. However, environmental releases, even under accident conditions, will be controlled and filtered. The potential on-site and off-site radiological consequences were evaluated for a release of the contents of a Spent Resin Storage Tank to the Auxiliary Building environment.

The Reactor Building basement and sump and Auxiliary Building tanks and sump may contain significant amounts of fission products, some fuel material, and sediment. It has been assumed for this evaluation that the accident occurs while the SRST contains the maximum estimated amounts of radioactivity (i.e., Reactor Building sump sediment). The SRST would contain radioactivity as presented in Table 4.

The SRST rupture is considered to release 2400 gallons of 43% by weight concentrated sediment to its respective cubicle. For illustrative purposes SRST "A" and its associated cubicle (AX009) will be used. The floor drain inside the cubicle can be assumed to be plugged with material spilled from the tank. The result of the spill is assumed to leave 50% of the sediment inside the cubicle with a layer of water one centimeter deep. The remaining sediment and contaminated water is assumed to spill into the adjacent area to the cubicles which include the SRST "B" cubicle (AX008), and the Spent Resin Transfer Pump cubicle (AX010). Water, other than a pool one centimeter deep in this area, is assumed to drain to the ABS by floor drains.

Release of airborne activity to the Auxiliary Building during a spill would be negligible in the areas outside the affected cubicle. The wet sediment combined with a water layer would prevent all but very minute amounts of the activity released to become airborne. Activity that does become airborne would be removed from the cubicle by the Auxiliary Building ventilation system.

4.3.5.1 Radiological Consequences of Tank Rupture - On-Site

On-site radiological consequences of the tank rupture have been analyzed to determine exposure rates for two conditions: 1) exposure rate at the opening of the enclosure adjacent to the SRST "A" cubicle due to the pool of contaminated water and sediment on the floor, and 2) exposure rate from the Auxiliary Building exhaust duct HEPA filters due to capture of the released airborne activity.

1. Pooled Water Radiation Field

This calculation is based on a worst case scenario which assumes that the SRST is filled with Reactor Building Sump Sediment at 43% by weight. Currently, the exact sediment volume at each source location is unknown, although the optimum concentration for sediment transfer is between 1 and 5% by weight sediment. At this concentration it would take several sediment transfers to achieve a 43% by weight sediment concentration.

The SRST "A" Cubicle is a 14'-0" by 16'-6" enclosure entered by way of a shielded door. The area was modeled for the ISOSHLD-II computer code for the purpose of calculating the radiation field due to the pool of sediment and water. Radiation field intensities were calculated at several distances above the surface of the pool: contact, 1-ft, 3-ft, 6-ft, and dose rate outside cubicle. The radiation dose rates calculated for this scenario are listed below. The expected radiation levels at lower concentrations would be significantly less. This conservative assumption bounds any possible worst case dose consequences from a SRST rupture.

contact-	886 R/hr
1-ft-	559 R/hr
3-ft-	271 R/hr
6-ft-	133 R/hr
Outside SRST Cubicle	2.8 E-07 R/hr

2. Aux Building Exhaust Plenum HEPA Filter Radiation Fields

As mentioned in the Submerged Demineralizer System Technical Evaluation Report (SDS TER), a dropped SDS liner was assumed to release 1.0E-04 of the contained activity to the Fuel Handling Building atmosphere. Similarly, it is assumed for this analysis that 1.0E-04 is released to the Auxiliary Building environment. This assumption is conservative because the spill being considered for

this analysis consists of a liquid-solids mixture and the mechanism of the spill is less violent than a cask drop. Additionally, the airborne activity that would be released from a liquid-solids spill would be significantly less than that from a dry powder spill.

The released airborne activity is expected to become entrained in the exhaust flow filter system. Therefore, the resulting primary gamma emitting isotopic quantities of $3.6E-03$ Ci of Cs-137 and $2.0E-04$ Ci of Cs-134 are assumed to be loaded on the HEPA filter banks.

In December 1981, an analysis was performed on the Reactor Building Purge Exhaust duct HEPA filter bank. At that time, the bank was determined to contain a total of 7.4 to 9.1 mCi of Cs-134 and 65-79 mCi of Cs-137. The resulting radiation levels were 10 mR/hr at the plenum side, 24 mR/hr on top of the plenum, and an average of 64 mR/hr on the face of the filter bank. Scaling these results to account for the activity released during a spill from the SRST, the accumulated amounts of Cs-134 and Cs-137 specified earlier would add the following increases to whatever activity was present on the filters at the time of the spill:

W mR/hr on side of plenum = 0.46 mR/hr

W mR/hr on top of plenum = 1.14 mR/hr

WmR/hr on filter face = 2.92 mR/hr

These radiation level increases are representative of a worst case accident and therefore bound any possible dose consequence from a SRST rupture.

4.3.5.2 Radiological Consequences of Tank Rupture - Off-Site

The off-site radiological consequences from the postulated SRST rupture were evaluated using the following assumptions:

- a. $1E-04$ of the sediment activity is released to the Auxiliary Building as airborne activity.
- b. Auxiliary Building HEPA filtration efficiency of 99%.
- c. SRST contains radionuclide concentrations as presented in Table 4.
- d. The X/Q values for the Exclusion Boundary and the low population zone are $6.1E-4$ and $1.1E-4$ sec/m³ respectively.

TABLE 4

Sediment Radionuclide Distribution

<u>Radionuclide</u>	<u>Concentration (mCi/gm)^a</u>	<u>Total Curies^b</u>	<u>Curies Released To Environment</u>
Sb-125	5.1E+0	2.3E+1	2.3E-5
Cs-137	8.0E+2	3.6E+3	3.6E-3
Cs-134	4.4E+1	2.0E+2	2.0E-4
Co-60	4.2E-1	1.9E+0	1.9E-6
Sr-90	6.5E+2	2.9E+3	2.9E-3
U-234	1.4E-4	6.3E-4	6.3E-10
U-238	1.1E-6	5.0E-6	5.0E-12
Pu-239, 240	4.7E-3	2.1E-2	2.1E-8
Pu-238	4.3E-4	1.9E-3	1.9E-9

a. IOM K. J. Hofstetter to Distribution, Analyses of R.B. Sump Samples, 4240-84-329, August 2, 1984.

b. Based on 43% by weight sediment concentrated in the SRST

TABLE 5

Off-site Dose Resulting From Postulated Spent
Resin Storage Tank Spill to the Auxillary
Building Environment

<u>Organ</u>	<u>Exclusion Boundary</u>	<u>Dose (Rem)</u>	<u>Low Population Zone</u>
Whole Body	5.16E-4		9.31E-5
Thyroid	4.28E-11		7.71E-12
Bone	8.38E-3		1.51E-3

As previously mentioned, at the time of the tank rupture, the tank contents will be wet. Consequently, the contents would not be expected to exhibit as great a tendency to become airborne. These conservative assumptions bound any possible dose consequence from a SRST rupture accident.

The off-site doses resulting from the postulated tank rupture were assessed using the dose conversion factors listed in NUREG-0172 (Ref. 25) and the organ dose calculation methodology consistent with Regulatory Guide 1.109 (Ref. 26). Table 5 presents the off-site doses for the whole body, thyroid and bone.

The bone dose is presented since it was determined to be the critical organ. The critical organ determination was made based on comparison of dose conversion factors for several organs, including the lung, kidney, liver and intestinal tract, for the distribution of radionuclides available for release.

5.0 10 CFR 50.59 Evaluation

Changes, Tests and Experiments, 10 CFR 50, para 50.59, permits the holder of an operating license to make changes to the facility or perform a test or experiment, provided that the change, test or experiment is not determined to be an unreviewed safety question and does not involve modification of the plant technical specifications.

A proposed change involves an unreviewed safety question if:

1. the probability of occurrence or the consequences of an accident or malfunction of equipment Important To Safety (ITS) previously evaluated in the safety analysis report may be increased; or
2. the possibility for an accident or malfunction of a different type than any evaluated previously in the safety analysis report may be created; or
3. the margin of safety, as defined in the basis for any technical specification, is reduced.

The Final Safety Analysis Report (FSAR) for TMI-2 evaluated a variety of postulated events to bound the range of possible events and their off-site dose consequences. Section 4.3.5 of this SER similarly analyzes a variety of events to bound the range of possible Sediment Transfer and Processing events and their off-site dose consequences. This evaluation proposes to compare similar events to demonstrate that TMI-2 activities are bounded by the TMI-2 FSAR.

The postulated SRST rupture accident evaluated in this SER was compared to the "Waste Gas Decay Tank Rupture": analyzed in Section 15.1.17 of the TMI-2 FSAR. This accident postulates the rupture of the waste gas decay tank and the consequent release of large quantities of gaseous fission products to the auxiliary building ventilation system and to the

environment through the unit vent. As reported in Table 15.1.17-2, of the TMI-2 FSAR, the accident resulted in an accumulated dose of 3.6 rem whole body for the two hour exclusion boundary and 0.57 rem whole body for the 30-day Low Population Zone (LPZ).

The rupture of a SRST has been analyzed in Section 4.3.5 of this SER. The radionuclides listed in Table 4 of this SER were assumed to be released to the Auxiliary Building ventilation system and subsequently to the environment through the unit vent. The accumulated doses resulting from this postulated event are reported to be $5.16E-4$ rem whole body for the two hour exclusion boundary and $9.31E-5$ rem for the 30-day LPZ. In addition, the critical organ dose for the assumed distribution of radionuclides was calculated to be $8.38E-3$ rem to the bone for the two hour exclusion boundary dose and $1.51E-3$ rem to the bone for the 30-day LPZ dose.

As can be seen, the dose consequences of the SRST rupture accident are far less than those resulting from the waste gas decay tank rupture accident. Although these events are not identical, both events evaluate the release of large quantities of fission products. Thus, they can be considered comparable. The accident analyses contained in the TMI-2 FSAR clearly bound the consequences of the SRST rupture accident postulated for sediment transfer and processing.

10 CFR 50.59 Review

To determine if the sediment transfer and processing operations involves an unreviewed safety question, the three key questions must be evaluated.

1. Has the probability of occurrence or the consequences of an accident or malfunction of equipment important to safety previously evaluated in the Safety Analysis Report been increased?

A variety of events have been analyzed in this SER. It has been demonstrated that postulated events with potential off-site dose consequences are substantially less than the potential consequences of comparable events analyzed. Also, by analysis of other postulated events, it has been demonstrated there are no events whose potential consequences exceed those analyzed in the TMI-2 FSAR.

By analyzing postulated events and reviewing various safety mechanisms, it has been determined that sediment transfer and processing operations will not adversely affect equipment classified as important to safety (ITS). Consequently, it is concluded that the probability of a malfunction of ITS equipment has not been increased.

2. Has the possibility for an accident or malfunction of a different type than any evaluated previously in the safety analysis report been created?

The variety of postulated events analyzed in this SER consider the spectrum of event types which potentially could occur during sediment transfer and processing operations. A comparison of these

events with those comparable events in the FSAR demonstrate that the type events postulated for the sediment transfer and processing operations are similar to and bounded by the FSAR. In addition, no new event has been identified which is different than those previously analyzed. Therefore, the sediment transfer and processing operations have not created the possibility of occurrence of an accident or malfunction of a different type than evaluated previously in the FSAR.

3. Has the margin of safety, as defined in the basis for any technical specification been reduced?

As demonstrated by this Safety Evaluation Report, Technical Specification safety margins will be maintained throughout the sediment transfer and processing operations. Since the operation of the sediment transfer and processing system and equipment are in accordance with approved procedures to ensure compliance to technical specifications, the tasks included in this SER will not reduce the margin of safety as defined in the basis for any technical specification.

The planned activities will not increase the probability of occurrence or consequences of an accident or malfunction of equipment important to Safety previously evaluated in the TMI-2 FSAR, TER's, SD's and SER's.

As a result of the above review, it is concluded that the sediment transfer and processing operations described in this SER are bounded by similar events postulated and analyzed in the TMI-2 FSAR and do not involve an unreviewed safety question as defined in Section 50.59 of 10 CFR Part 50.

6.0 ENVIRONMENTAL ASSESSMENT

The sediment transfer and processing activities have been assessed and it is concluded that these activities will be performed with no unacceptable consequences to the health and safety of the public or workers.

Releases to the public resulting from planned sediment transfer and processing activities are expected to be significantly less than releases during previous work conducted in the reactor building or the AFHB. Past releases of radioactivity to the environment have been well within the limits of the TMI-2 Environmental Technical Specifications.

Potential off-site dose consequences resulting from a Spent Resin Storage Tank rupture have been evaluated. This is an instantaneous release of 2400 gallons of concentrated radioactive sediment to the SRST cubicle (Section 4.3.5). In this evaluation the analyses were performed using extremely conservative assumptions in order to provide bounding results. Using the conservative assumptions the results were found to be within past analyses that have been found to have acceptable consequences. The potential off-site dose consequences of a Waste Gas Decay Tank rupture were evaluated in the FSAR section 15.1.17. The rupture of this tank would release more radioactivity to the environment than any other credible radwaste system accident and therefore was used as the bounding conditions for this evaluation. The dose rate consequences of a SRST

rupture accident are significantly less than those resulting from a waste gas decay tank rupture accident. (Section 4.3.5.2) The radioactive release of a SRST rupture accident was found to be less than 1% of the 10CFR100 dose guidelines for accidents.

As stated in Reference 9, the most significant environmental impact associated with the cleanup of TMI-2 will result from the radiation doses received by the entire work force from cleanup activities. The environmental impact from the cleanup of TMI-2 resulting from occupational exposure has been reevaluated by the NRC in supplement no. 1 to Reference 9. This reevaluation estimates an occupational exposure in the range of 13,000 to 46,000 person-rem with AFHB and Reactor Building cleanup activities contributing 6,400 to 22,400 person-rem. The total occupational exposure associated with the installation and operation of the sediment transfer and processing system has been estimated to be approximately 58 person-rem. Thus, the estimated occupational exposure from the activities outlined in the SER are bounded by Reference 9.

Therefore, the planned sediment transfer and processing activities will be performed with no significant environmental impact.

7.0 REFERENCES

1. ANSI B31.1 "American National Standard Code for Pressure Piping," 1973 Edition
2. Regulatory Guide 1.143, "Design Guidance for Radioactive Waste Management Systems, Structures and Components Installed in Light-Water Cooled Nuclear Power Plants," Revision 1, October 1979
3. GPUN Drawing 2D-3233-1038. Sediment Transfer System Piping and Instrument Diagram
4. GPUN Drawing 2D-3233-1039, Sediment Transfer System Hose Routing and Details
5. GPUN Drawing 2C-3233-1030. STS Manway Covers for MHHT and ABST.
6. RPOD-3233-001, Sediment Transfer System Operating Description
7. RPOD-3233-002, Sediment Processing System Operating Description
8. Final Safety Analysis Report - Three Mile Island Nuclear Station, Unit 2, Docket No. 50-320, Metropolitan Edison Co., Jersey Central Power and Light Co., Pennsylvania Electric Company
9. NUREG-0683, Final Programmatic Environmental Impact Statement, March 1981.
10. Code of Federal Regulations, Title 10 Part 50.59, Domestic Licensing of Production and Utilization Facilities: Changes, Tests and Experiments, 42 FR 20139, April 18, 1977
11. Criticality Handbook, Vol. II, Atlantic Richfield Hanford Co.

12. Critical Dimensions of Systems Containing U-235, Pu-239, and U-233. TID-7028, Figure 21, USAEC, 1964
13. NUREG/CR-2139, "Aerosols Generated by Free Fall Spills of Powders and Solutions in Static Air," December 1971
14. Calculation of Doses Due to Accidentally Released Plutonium from an LMFB, R.R. Fish et al., November 1972, ORNL-NSIC-74
15. "Auxiliary Building Sump, Sump Tank, and Valve Gallery Reactor Fuel Quantification," Technical Bulletin 86-28
16. "Radioactive Sediment Processing," Technical Plan, TPO/TMI-084, December, 1983
17. "Sediment Removal and Transfer System," Planning Study, TPO/TMI-083, October 1983
18. "Ex-RCS Criticality Safety," Technical Plan, TMI/TPO-132, November, 1985
19. "Auxiliary and Fuel Handling Building Decontamination," Technical Plan, TPO/TMI-130, March 1985
20. RPOD-3233-003, Decant System Operating Description
21. GPUN Drawing 2E-3233-1035, Sediment Processing System P&ID
22. GPUN Drawing 2D-3233-1043, Decant System P&ID
23. GPUN Drawing 2D-3233-1049, Reactor Building Sediment Removal P&ID
24. "Reactor Building Sump Criticality Safety Evaluation Report" GPU Nuclear SER, SA. No. 4550-3254-85-02, Aug. 1985.
25. NUREG-0172, "Age Specific Radiation Dose Commitment Factors for a One-Year Chronic Intake". November 1977.
26. Regulatory Guide 1.109, "Calculation of Annual Doses to Man from Routine Releases of Reactor Effluents for the Purpose of Evaluating Compliance with 10 CFR 50, Appendix I", Rev. 1, October 1977.
27. "Rinse and Elution of Makeup and Purification Demineralizer Resins" GPU Nuclear SER, SA. No. 4340-3211-84-0054, July 1984.